

### STANDARD EQUIPMENT

10 YEAR LIMITED WARRANTY  
 All Aluminum Construction w/ an Extruded Floor, Rub Rail & Tie Rail,  
 2" X 3" Extruded Tubing Crossmember on 16" Centers for Maximum Torsional Rigidity ,  
 2 – 3500 lb Torsion Axles, 15" Aluminum Wheels w/ ST205/75R 15D Tires,  
 GVWR Rating 7770 lbs, 2000 lb Rated Tongue Jack, LED Lighting,  
 2 5/16" Coupler. 16" Height, Safety Chains & Safety Breakaway System,  
 4 – 6,000 lb Rated Tie Downs, 20" Load Height,  
 7' 6" X 12" Wide HD Ramps (2000 lb Each) Weighing 31 lb. Each,  
 2 – Hillsboro Exclusive Drop Down Rear Stabilizer Jacks  
 2 – Removable Aluminum Fenders – 82 ½" Between Fenders



### 2 RAMP

ITEM	DESCRIPTION	AXLE	WEIGHT(LBS)	GVWR	REF#	LIST PRICE
75100	AOCT3.5K-16 2R F/G	2-3.5K	1300	7770	AL680NE19	\$ 11,194
75101	AOCT3.5K-18 2R F/G	2-3.5K	1350	7770	AL780NE84	\$ 11,408
75102	AOCT3.5K-20 2R F/G	2-3.5K	1400	7770	AL980NE49	\$ 11,622

### 3 RAMP

ITEM	DESCRIPTION	AXLE	WEIGHT(LBS)	GVWR	REF#	LIST PRICE
75100-003	AOCT3.5K-16 3R F/G	2-3.5K	1380	7770	AL290NE22	\$ 11,977
75101-003	AOCT3.5K-18 3R F/G	2-3.5K	1430	7770	AL390NE89	\$ 12,194
75102-003	AOCT3.5K-20 3R F/G	2-3.5K	1480	7770	AL590NE54	\$ 12,408

### ACCESSORIES AND OPTIONS (Not Installed)

ITEM	DESCRIPTION	REF#	LIST PRICE
75246	AOCT Stone Guard Kit	KI800KI23	\$ 1,069
75250	AOCT Bumpail Kit	KI100KI78	\$ 231
75257	AOCT Winch mount Kit	KI000KI79	\$ 103
234292	TIRE & WHEEL ST205/75R15D W/AL LION	Castle Rock, 3500 LB AXLE	TI200WH16 \$ 281
75290	AOCT Tongue Toolbox Kit	KI900KI58	\$ 1,244

### STANDARD EQUIPMENT

10 YEAR LIMITED WARRANTY  
 All Aluminum Construction w/ an Extruded Floor, Rub Rail & Tie Rail,  
 2" X 3" Extruded Tubing Crossmember on 16" Centers for Maximum Torsional Rigidity ,  
 2 – 5200 lb Torsion Axles, 15" Aluminum Wheels w/ ST225/75R 15E Tires,  
 GVWR Rating 9990 lbs, 2000 lb Rated Tongue Jack, LED Lighting,  
 2 5/16" Coupler. 20" Height, Safety Chains & Safety Breakaway System,  
 4 – 6,000 lb Rated Tie Downs, 21.5" Load Height,  
 6' X 12" Wide HD Ramps (2500 lb Each) Weighing 25.4 lb. Each,  
 2 – Hillsboro Exclusive Drop Down Rear Stabilizer Jacks  
 2 – Removable Aluminum Fenders – 82 ½" Between Fenders



### 2 RAMP

ITEM	Description	AXLE	WEIGHT(LBS)	GVWR	REF#	LIST PRICE
75111	AOCT5.2K-18 2R F/G	5.2K	1680	9990	AL301NE59	\$ 13,453
75112	AOCT5.2K-20 2R F/G	5.2K	1730	9990	AL601NE70	\$ 13,857
75113	AOCT5.2K-22 2R F/G	5.2K	1780	9990	AL011NE36	\$ 14,332
75114	AOCT5.2K-24 2R F/G	5.2K	1830	9990	AL311NE48	\$ 14,738

### 3 RAMP

ITEM	Description	AXLE	WEIGHT(LBS)	GVWR	REF#	LIST PRICE
75112-003	AOCT5.2K-20 3R F/G	5.2K	1810	9990	AL211NE75	\$ 14,643
75113-003	AOCT5.2K-22 3R F/G	5.2K	1860	9990	AL611NE39	\$ 15,116
75114-003	AOCT5.2K-24 3R F/G	5.2K	1910	9990	AL911NE51	\$ 15,521

### ACCESSORIES AND OPTIONS (Not Installed)

ITEM	Description	REF#	LIST PRICE
75246	AOCT Stone Guard Kit	KI800KI23	\$ 1,069
75250	AOCT Bumptrail Kit	KI100KI78	\$ 231
75257	AOCT Winch mount Kit	KI000KI79	\$ 103
234293	TIRE & WHEEL ST225/75R15E W/AL LION	Castle Rock, 5200 LB AXLE	MI200 P62 \$ 340
75290	AOCT Tongue Toolbox Kit	KI900KI58	\$ 1,244

DIMENSIONS (INCHES)			
MODEL #	DIM X	DIM L	AXLE CENTER
CH16RD	192	244	78
CH18RD	216	268	90
CH20RD	240	292	102

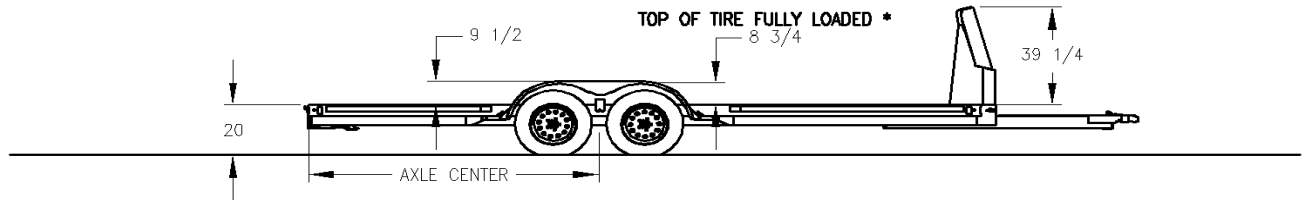
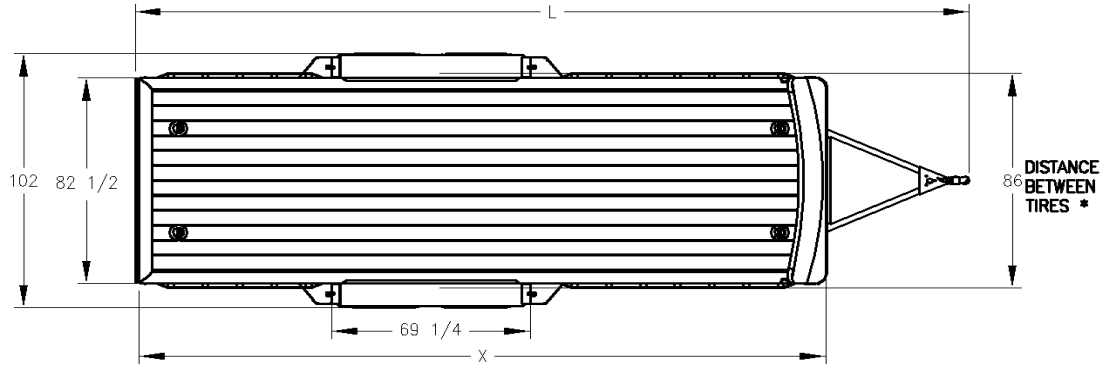

ALL DIMENSIONS ARE APPROXIMATE FOR  
STANDARD TRAILER IN UNLOADED CONDITION

SHOWN WITH OPTIONAL AERO GUARD  
\* WHEN FENDER REMOVED

TITLE RD ALUMINUM CAR HAULER						Hillsboro Industries 220 Industrial Road Hillsboro, KS 67063	1-800-835-0209 hi@hillsboroindustries.com www.hillsboroindustries.com
DWG NO. ?????	REV A	DATE 6-18	DRAWN BY APD	SCALE 1/50	PAGE 1 OF 1		

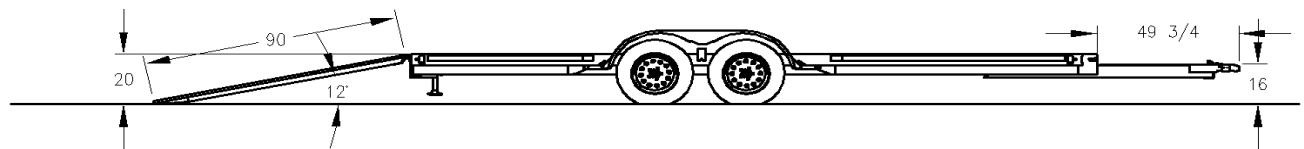

ALL DIMENSIONS ARE APPROXIMATE FOR  
STANDARD TRAILER IN UNLOADED CONDITION

TITLE RD ALUMINUM CAR TRAILER						Hillsboro Industries 220 Industrial Road Hillsboro, KS 67063	1-800-835-0209 hi@hillsboroindustries.com www.hillsboroindustries.com
DWG NO. ?????	REV A	DATE 6-18	DRAWN BY APD	SCALE 1/50	PAGE 1 OF 1		

DIMENSIONS (INCHES)			
MODEL #	DIM X	DIM L	AXLE CENTER
CH20HD	240	292	102
CH22HD	264	316	108
CH24HD	288	340	114

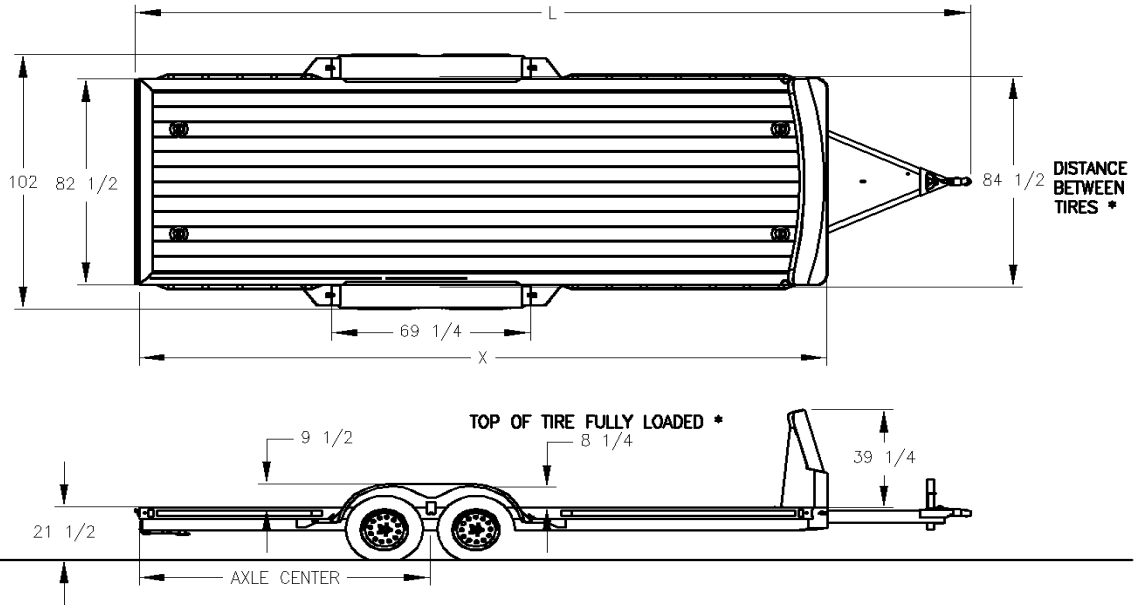

ALL DIMENSIONS ARE APPROXIMATE FOR  
STANDARD TRAILER IN UNLOADED CONDITION

SHOWN WITH OPTIONAL AERO GUARD  
\* WHEN FENDER REMOVED

TITLE HD ALUMINUM CAR HAULER						Hillsboro Industries 220 Industrial Road Hillsboro, KS 67063		1-800-835-0209 hi@hillsboroindustries.com www.hillsboroindustries.com	
DWG NO. ?????	REV A	DATE 12-18	DRAWN BY APD	SCALE 1/50	PAGE 1 OF 1				

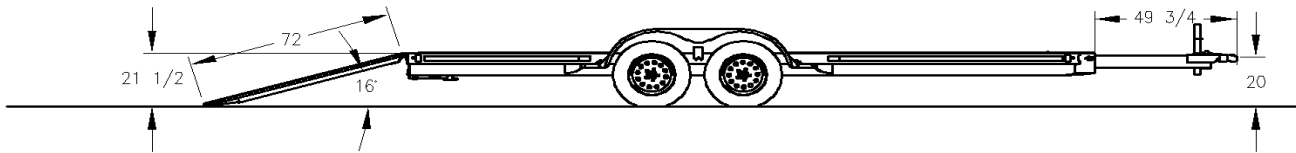

ALL DIMENSIONS ARE APPROXIMATE FOR  
STANDARD TRAILER IN UNLOADED CONDITION

TITLE HD ALUMINUM CAR TRAILER						Hillsboro Industries 220 Industrial Road Hillsboro, KS 67063		1-800-835-0209 hi@hillsboroindustries.com www.hillsboroindustries.com	
DWG NO. ?????	REV A	DATE 12-18	DRAWN BY APD	SCALE 1/50	PAGE 1 OF 1				